

# OGP RANGE

## Outdoor Call Help Point Tower

### OGP SERIES OUTDOOR HELP POINT TOWER

- OGP-10 - 9' Free Standing Tower

### FEATURES and BENEFITS

- 316 stainless steel base is designed to breathe out condensation to prevent internal moisture build up within the pole.
- Integrate DIN mounting system to allow for 3rd party equipment (ie: media converters, switches ...).
- Removable sealed service panels (with security screws) to access internal systems.
- Large radius rounded corners for impact safety.
- Panel area has overhead LED illumination.
- Panels are reverse mounted to eliminate exposed screws.
- Large bright beacon – 360° viewable. Operational modes are user selectable.
- High impact beacon lens, UV protected for long life.
- Supports optional overhead camera mount.
- Dual coating; Safety Yellow exterior UV protected, with corrosion resistant primer.
- Large visible signage on 2 sides. Content user definable.
- Panel area supports Guardian's HDE Series of Analog and VoIP Help Point hands-free devices.

- **HDE SERIES ANALOG HEAVY DUTY EMERGENCY & PUBLIC ACCESS TELEPHONES**

- HDE-11/11 – Recessed/Single Emergency/ 0.25 Watt / 3.0 Watt\*\*
- HDE-1100 – Recessed/Single Call Button & 12 Digit Keypad/ 0.25 Watt / 3.0 Watt\*\*

- **HDE-V SERIES VoIP HEAVY DUTY EMERGENCY & PUBLIC ACCESS TELEPHONES**

- HDE-11-V – Recessed/Single Emergency/ 0.5 Watt.
- HDE-1100-V – Recessed/Single Call Button & 12 Digit Keypad.

### OGP RANGE OF HELP POINT DEVICES

Guardian's OGP (On-Guard Protector) RANGE of Heavy Duty Emergency Industrial Help Point Telecommunication Devices and Towers, combined with Guardian's HDE Series of Analog and VoIP Help Point hands-free devices are intended for use in public areas where direct / emergency assistance or hands-free communication is required.

### HDE SERIES OF TELEPHONES

Guardian's HD SERIES Heavy Duty Emergency Industrial Telephones the Guardian HDE SERIES (Analog) and HDE-V SERIES (VoIP) telephones provide a two-way link to emergency, access or information assistance through full-duplex phone transmission. A call may be initiated from the phone by pushing the button which routes the call to its assigned extension. These phones also provide the capability of monitoring the status of each unit from a remote location, informing personnel of a malfunction.

### APPLICATIONS

The OGP Outdoor Help Point Tower was designed to provide reliable communications in environments subject to vandalism, moisture, dust and corrosive chemicals such as:

- |                     |                        |
|---------------------|------------------------|
| Universities        | Public Access Areas    |
| Business Campuses   | Parks                  |
| Building Entrances  | Plant Entry Gates      |
| Parking Facilities  | Amusement Parks        |
| Sporting Facilities | Senior Citizen Housing |
| Transit Authorities | Medical Centers        |
| Industrial Parks    | and more ...           |



tough. trusted. true.



## OVERALL DIMENSIONS

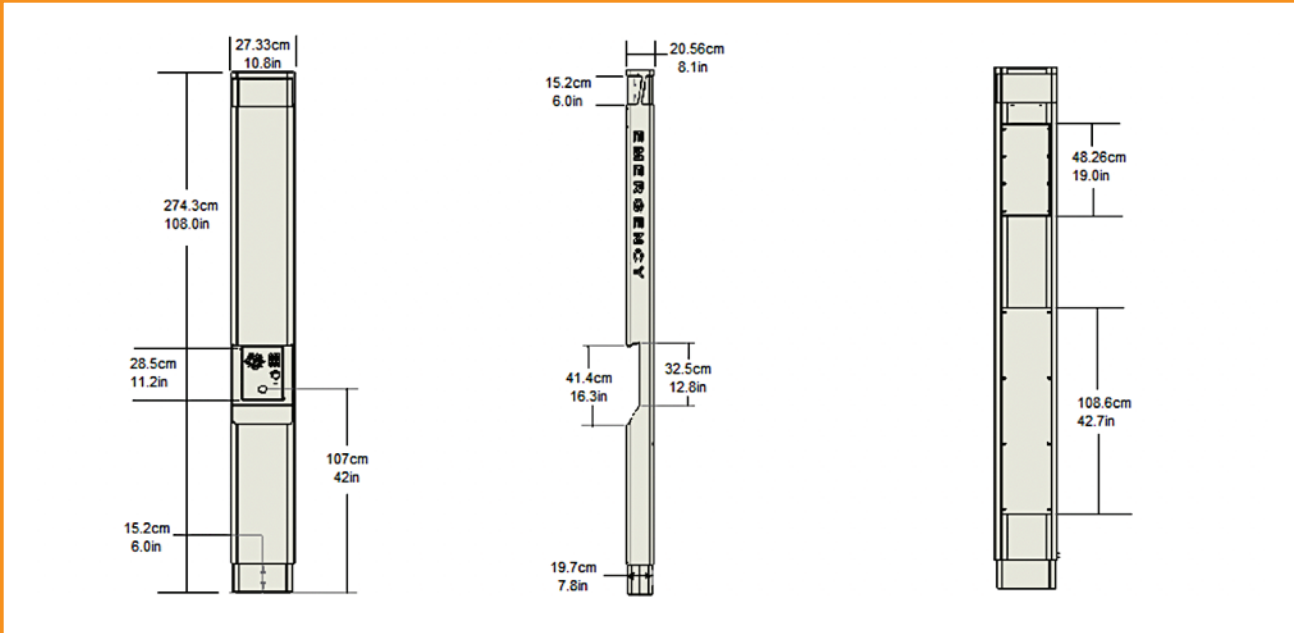

OGP SERIES OUTDOOR HELP POINT TOWER

## ENGINEERING SPECIFICATIONS

### ELECTRICAL REQUIREMENTS

Beacon/Lighting: 120/240VAC or 24VDC @ nAmps  
 If using SIP/IP Communications 24VDC@1A or POE 802.11aF\*  
 If using analog Communications Telephone line powered and/or +12VDC @ 0.5A\*\*

\*Contact Guardian Telecom for IP power requirements based on options and configuration for IP Products.

\*\*Adding supplemental power to the analog communications products provides additional features and capabilities.

### MECHANICAL SPECIFICATIONS

Pole Material Cold Rolled Steel – 11 Gauge  
 Pole Base Material 316 Stainless Steel – 16 Gauge  
 Weight: 120lbs, 54.5Kgs  
 Overall Dimensions 11"W x 8.1"D x 108"H  
 279mm x 206mm x 2743mm  
 Communication Panel Area 11"W x 12.9"H  
 279mm x 327mm  
 Beacon Viewable Area 6"H 152mm  
 Access Panels Qty 2 – Lower (42") and Upper (19")  
 Integrated DIN Rail STD 2" - 19" length

### PRODUCTS SUPPORTED

#### HDE SERIES ANALOG HEAVY DUTY EMERGENCY & PUBLIC ACCESS TELEPHONES

HDE-11 – Recessed/Single Emergency/ 0.3 Watt.\*\*  
 HDE-1100 – Recessed/Single Call Button & 12 Digit Keypad/ 0.3 Watt\*\*

#### HDE-V SERIES VoIP HEAVY DUTY EMERGENCY & PUBLIC ACCESS TELEPHONES

HDE-11-V – Recessed/Single Emergency/ 0.5 Watt  
 HDE-1100-V – Recessed/Single Call Button & 12 Digit Keypad/ 0.5 Watt

Industry Standard Insert Panels easily accepted.

### ENVIRONMENTAL

Pole IP-65 Weather proof rating  
 Base 316 Stainless Steel.  
 Painted surfaces Powder coat with dual coating, corrosion resistive primer.  
 Exterior finish UV stabilized.  
 Telecom Panels 316 Stainless Steel  
 Electronics: -40C to +70C

### COMPLIANCE

CSA/UL 60950-1 – Safety  
 Weather Rating IP-65 / Nema 4  
 ADA Refer to insert datasheets for communications device compliance

### ORDERING INFORMATION

Warranty: 3 year parts and labor

Order No.	Description
Pxxxx	OGP-10 9' Free Standing Tower
<b>Options</b>	
OHCM	Overhead Camera Mount
HL	Hearing Loop Antenna
	External Antenna Required - Contact Guardian Telecom

Distributed by:



GUARDIAN TELECOM, a division of CIRCA ENTERPRISES INC.  
 Calgary, Alberta, Canada  
 Telephone: 1 403 258-3100 Facsimile: 1 403 255-2595  
 Toll Free: 1 800 363 8010 (North America)  
 info@guardiantelecom.com | www.guardiantelecom.com