

# Smart Cabinet Access System

Product Bulletin  
PB0005

The cost-effective access control system that offers superior reliability, flexible implementation and enhanced management for maximum security at the cabinet and room level.

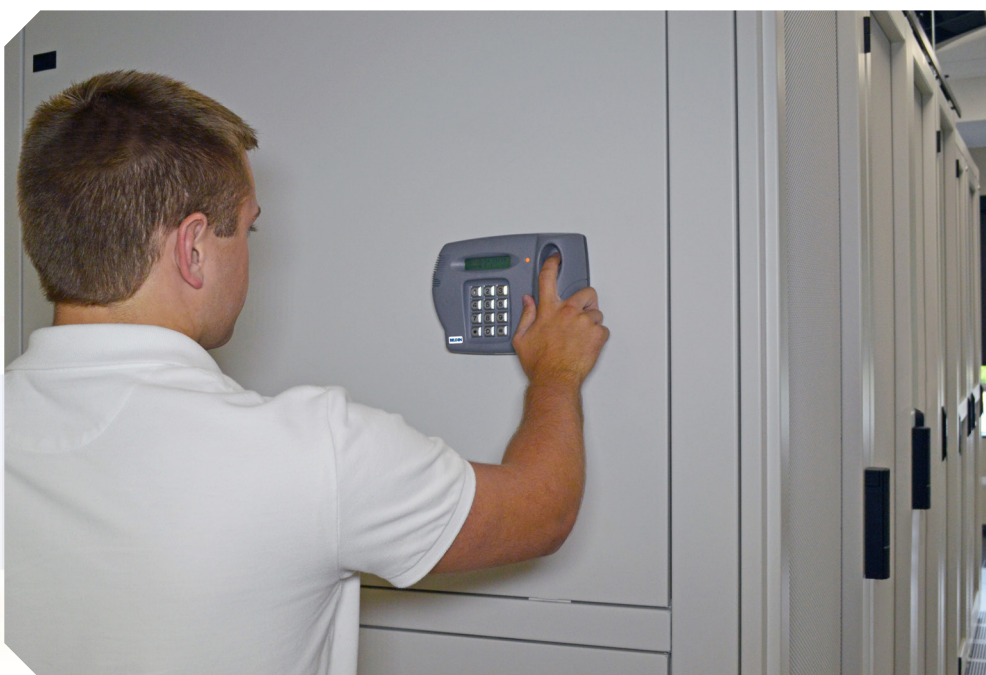

## FASTER

- Faster implementation via IP-based networked controllers
- Faster installation with durable, compact components
- Faster system deployment with centralized design and UTP cable

## EASIER

- Easier management through intuitive access management software
- Easier configuration for room, cabinet, row or pod access
- Easier retrofitting to any cabinet using standard footprint handles

## BETTER

- Better reliability through encryption and redundancy
- Better security with iClass and biometrics handle options
- Better regulatory compliance (HIPPA, PCI DSS, FISMA, SSAE 16)

Our End-to-End Expertise  
Your End-to-End Solution

## Smart Cabinet Access System

### KEY FEATURES

- Central administration of up to thousands of units
- 100% indisputable audit trails when using biometric option
- Real-time access monitoring and alerts
- Advanced management and configuration options
- SNMP for integration with other systems
- Retrofit capability to most enclosures
- Fully encrypted communication

Available on all Belden X-Series enclosures for servers and networking equipment, the Belden Smart Cabinet Access System is an advanced networked access control system that features a variety of implementation configurations and enhanced management capabilities for secure access to critical networking equipment in data centers and colocation centers. With internal threats accounting for more than 60% of today's security breaches, the access system offers improved security where it's needed most—at the cabinet level. It also allows for row, pod and room access control, enabling complete site access control from a single platform.

Field proven in a variety of mission critical networking environments, the Smart Cabinet Access System provides indisputable audit trails and real-time monitoring and alerts for the highest level of data center security and regulatory compliance (HIPAA, PCI DSS, FISMA, SSAE 16 and more). The intelligent IP-based nature of the access system significantly cuts deployment and operating costs, enables easy integration with other systems and offers enhanced centralized administration for virtually any number of cabinets and users.

## Better Security with Cost-Effective Implementation and Operation

### Scalable and Flexible

Using multiple centralized IP-based networked controllers, the Smart Access System is scalable to administer and manage access control for up to thousands of cabinets across multiple facilities. A single centralized IP-based network controller can control access to up to 32 cabinets (remote nodes).

Each node can support two Smart Handles per cabinet for separate access control at front and back doors. The optional Enline Reader, which counts as a node, allows authentication to be accomplished for a group of cabinets (e.g., Row, POD).



BUS Enline Reader w/PIN and Fingerprint Access

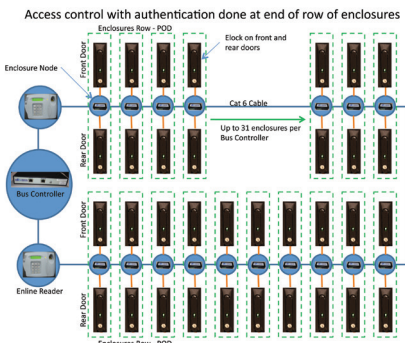
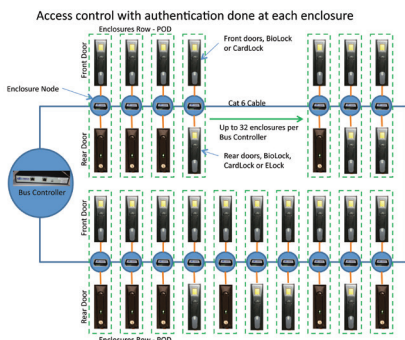

### Easy, Reliable Deployment

The compact controllers and nodes are easily mounted in the cabinet without taking up valuable rack unit space. Nodes are connected to their controller using a loop bus topology via category UTP cable (e.g., Category 5e and Category 6), significantly reducing cost compared to decentralized systems. Communication between nodes and their controller use an encryption protocol, and each controller communicates with the network via encrypted TCP/IP communications.

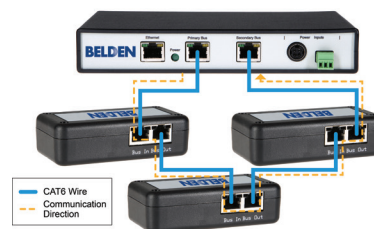

The loop bus provides redundancy for the connected nodes—if the bus connection is broken, the controller re-routes the signal and power in the opposite direction and immediately alerts the system. During network downtime, up to 6000 events can be logged locally at each node and later uploaded to the centralized system.

In the event of a power failure, Smart Handles automatically lock, requiring the visible plastic lock seal to be broken and use of a master bypass key to access the cabinet. The smart swing handles are compatible with both single-point and 3-point latching doors.

Our End-to-End Expertise.  
Your End-to-End Solution.

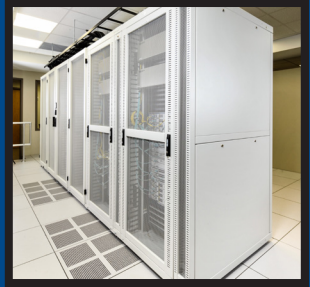

## Multiple Smart Handle Options to Meet Specific Security Needs and Compliance

### iClass Card

iClass Card Smart Handles use the latest high-frequency iClass RFID technology with fast, encrypted bi-directional communication between the card and the reader for superior authentication and enhanced security over keyed locks or standard low-frequency proximity cards that can be easily copied and duplicated. The system can be used with existing iClass card systems to significantly cut down on on deployment costs for facilities that already have these systems in place.

### Biometrics

The Biometric Smart Handle features advanced vector fingerprint scanning technology and enables a 100% indisputable audit trail to achieve maximum compliance with security regulation requirements. The biometric template created during registration is vectorized before stored and can not be used to reconstruct an individual's fingerprint image.

### E-Lock

The E-Lock handle is a slave handle that unlocks with authorized access at an iClass or Biometric handle, it is typically used on the cabinet rear door allowing cost effective deployment. When used with the Enline Reader for pod- or row-level access, the E-Lock handle is typically used on both front and rear cabinet doors.

Smart Handles feature a standard cut-out footprint that allows the system to be easily retrofitted to most existing non-Belden cabinets.



iClass Card, Biometrics and E-Lock Handle Options

## Enhanced Security Features and Management Capabilities

The Smart Cabinet Access System features intuitive management software for managing and monitoring up to thousands of IP-based controllers and their nodes. The access system receives, stores and alerts access attempts in real time. Non-authorized access attempts will generate alarms to security personnel, potentially leading to full system lock down. The management software is used to set up, configure and define the parameters of the system to suit unique needs and environments, including types of users, groups, zones, time band and reporting functions.

The ability to establish smaller virtual zones with associated partition administrators is ideal for allowing tenants to manage their specific cabinets/cage access within a colocation center.

- Various user types, including administrator, partition administrators, security and standard users
- High-security dual custody settings where two users must be present to authenticate access
- Ability to assign users to user groups with access to specific doors within established timebands
- Zoning feature for grouping controllers/cabinets into smaller zones to facilitate management and reporting
- Generation of custom, detailed reports for compliance with security regulation auditing requirements

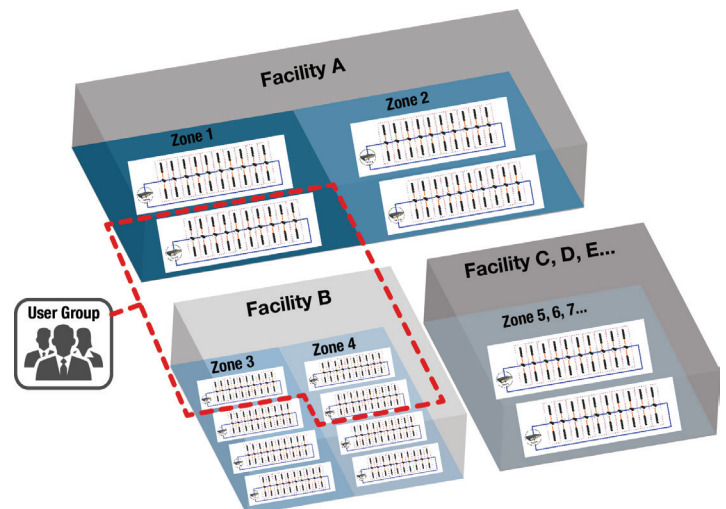

## Easier System Integration

### To Learn More...

For more information call **1.800.BELDEN.1** (1.800.235.3361) or visit our web site at [www.belden.com](http://www.belden.com) for more information on the Smart Cabinet Access System.

The IP-based nature of the Smart Cabinet Access System and the software's simple network management protocol (SNMP) allow the system to easily integrate and exchange information with other systems that reside on the network, such as Belden's Cormant DCIM solution and other security and building automation systems.

When combined with the Belden Adaptive Enclosure Heat Containment System, intelligent power distribution units and environmental monitoring solutions that can also integrate with Cormant DCIM, the Smart Cabinet Access System rounds out the line of Belden DCIM-ready solutions for an overall smarter, more secure computing space. Belden experts can also help you define the primary objectives of a security plan and choose the design, configuration and solutions that best suit the needs of your data center or colocation center.



## Ordering Information

Description	Belden Part Number
<b>Access System Controller</b>	
BUS Controller, incl. 48 VDC PSU	8815-0200
<b>End of Rows Reader</b>	
BUS Enline reader w/PIN and Fingerprint	8815-0210
BUS Enline reader w/PIN, Fingerprint and HID iCLASS 13.56 MHz	8815-0211
BUS Enline reader w/PIN, Fingerprint and HID 125 KHz	8815-0212
<b>Enclosures Level &amp; Row Level Access Systems - Networked application</b>	
Enclosure node with 1 Biolock swing handle	8815-0221
Enclosure node with 1 Biolock and 1 Elock swing handle	8815-0222
Enclosure node with 2 Biolocks swing handle	8815-0223
Enclosure node with one 1 iClass Cardlock swing handle	8815-0224
Enclosure node with 1 iClass Cardlock and 1 Elock swing handle	8815-0225
Enclosure node with 2 iClass Cardlocks swing handle	8815-0226
Enclosure node with 1 Elock swing handle	8815-0227
Enclosure node with 2 Elocks swing handle	8815-0228
<b>Enclosures Level Access Systems* - Stand alone application - Networked or not</b>	
Access controller/enroller with 1 Biolock and 1 Elock swing handle	8815-0246
Access controller/enroller with 1 iClass Cardlock and 1 Elock swing handle	8815-0247
Power supply for controller/enroller unit	8815-0249
<b>Building, Room Level Access Systems**</b>	
Door level access controller, Biometric and Pin pad credential options	8815-0270
Door level access controller, Biometric, Proximity card and Pin pad credential options	8815-0271
<b>Software - Access Interface and Management</b>	
Server/client software for connection up to 10 enclosures	8815-0280
Server/client software for connection up to 50 enclosures	8815-0282
Server/client software for connection up to 100 enclosures	8815-0283
Server/client software for connection up to 250 enclosures	8815-0284

\* Enclosure level access system have build in controller and software package.

\*\* Compatible with most electronic door handles